

BMM Snatch blocks

Galvanized

Part no.	WLL 5:1 ton	Max load on headfitting ton	Test load ton	A mm	B mm	D mm	E mm	F mm	G mm	I mm	Weight kg
KS110- * E	3.0	6.0	12.0	255	85	110	68	85	70	45	10.0
KS150- * E	5.0	10.0	20.0	330	85	150	75	85	110	55	19.2
KS215- * E	8.0	16.0	32.0	425	100	215	95	100	170	63	39.5

All snatch blocks must be closed during operation.

BMM-Blocks must be ordered with one of the following:

- 1 Ball bearing, greaseable.
- 0 Bronze bushing, greaseable.

On order replace * with letter, e.g. KS110-1EG

Against extra charge all blocks are available with:

- C Tested with certificate.
- P Split pin at locking device.

On order add letter, e.g. KS40EGC



Split pin in locking device.

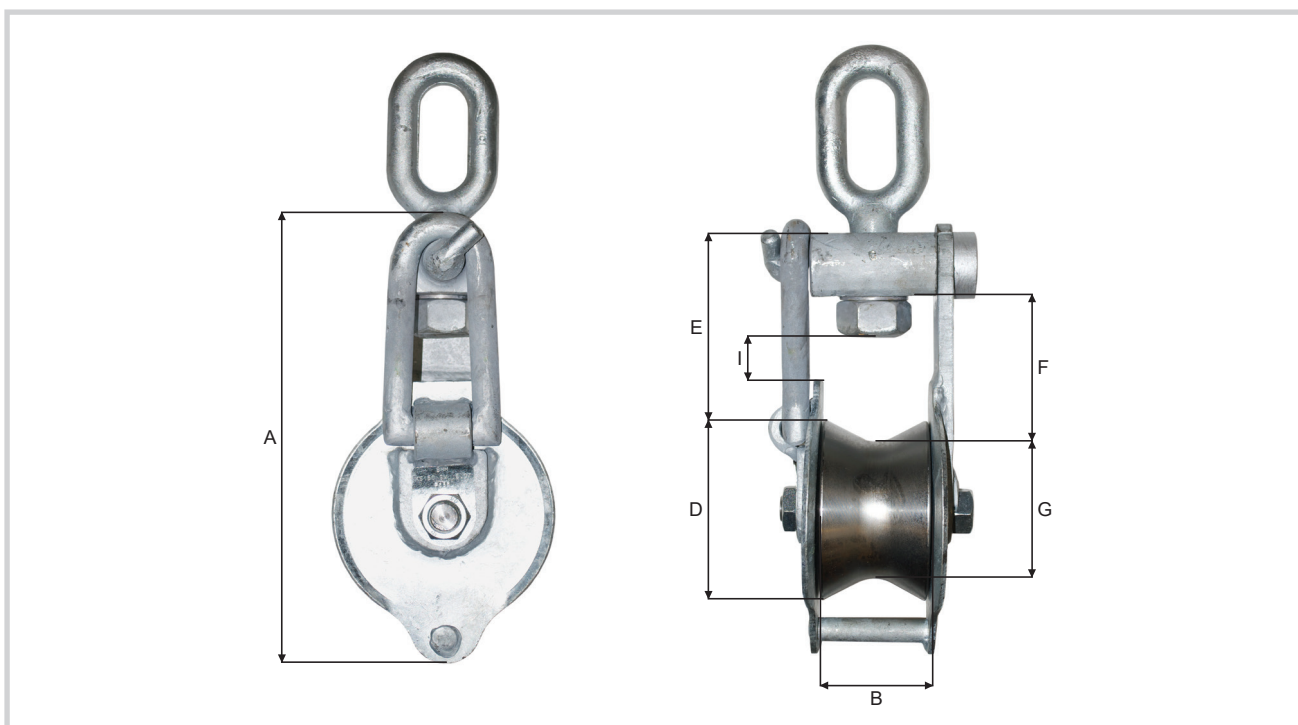

Top fittings

Swivel eye

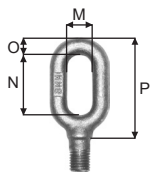

Part no.	M mm	N mm	O mm	P mm
KS110	33	82	24	134
KS150	40	95	28	153
KS215	45	86	32	181

Sheaves

Ball bearing

Part no.	B mm	D mm	R mm	S mm	Weight kg
SKS110-1	85	110	62	25	3.60
SKS150-1	85	150	62	25	8.10
SKS215-1	100	215	80	35	18.30

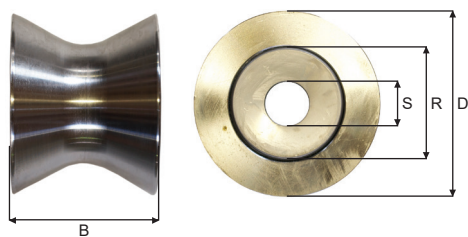

Bronze bushing

Part no.	B mm	D mm	S mm	Weight kg
SKS110-0	85	110	25	3.80
SKS150-0	85	150	25	8.20
SKS215-0	100	215	35	18.50

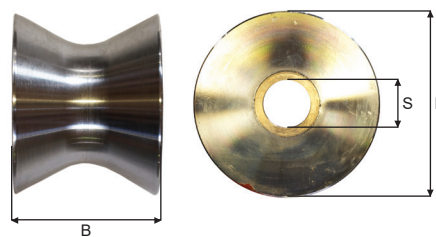

Pins

Ball bearing

Part no.	X mm	Y mm	Z mm	Weight kg
PKS110-1	144	25	115	0.60
PKS150-1	154	25	122	0.70
PKS215-1	158	35	117	1.30

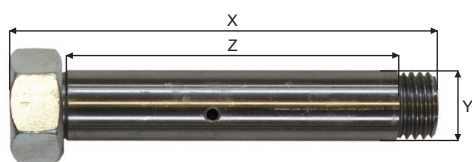

Bronze bushing

Part no.	X mm	Y mm	Z mm	Weight kg
PKS110-0	144	25	115	0.60
PKS150-0	154	25	122	0.70
PKS215-0	158	35	117	1.30

